

**MOD-IMGSX550-D**  
**Industrial 1.25Gbps SFP Optical**  
**Transceiver (MM, 550m)**



**Features**

- Data-rate of 1.25Gbps operation
- 850nm VCSEL laser and PIN photodetector
- Compliant with SFP MSA and SFF-8472 with duplex LC receptacle
- Digital Diagnostic Monitoring:  
 Internal Calibration or External Calibration
- 500m transmission with 50/125µm MMF
- 300m transmission with 62.5/125µm MMF
- Compatible with RoHS
- +3.3V single power supply
- Operating Temperature : -40 to +85°C

**Applications**

- Gigabit Ethernet
- Fiber Channel
- Switch to Switch interface
- Switched backplane applications
- Router/Server interface
- Other optical transmission systems

## Description

The SFP transceivers are high performance, cost effective modules supporting data-rate of 1.25Gbps and 550m transmission distance with MMF.

The transceiver consists of three sections: a VCSEL laser transmitter, a PIN photodiode integrated with a trans-impedance preamplifier (TIA) and MCU control unit. All modules satisfy class I laser safety requirements.

The transceivers are compatible with SFP Multi-Source Agreement (MSA) and SFF-8472. For further information, please refer to SFP MSA.

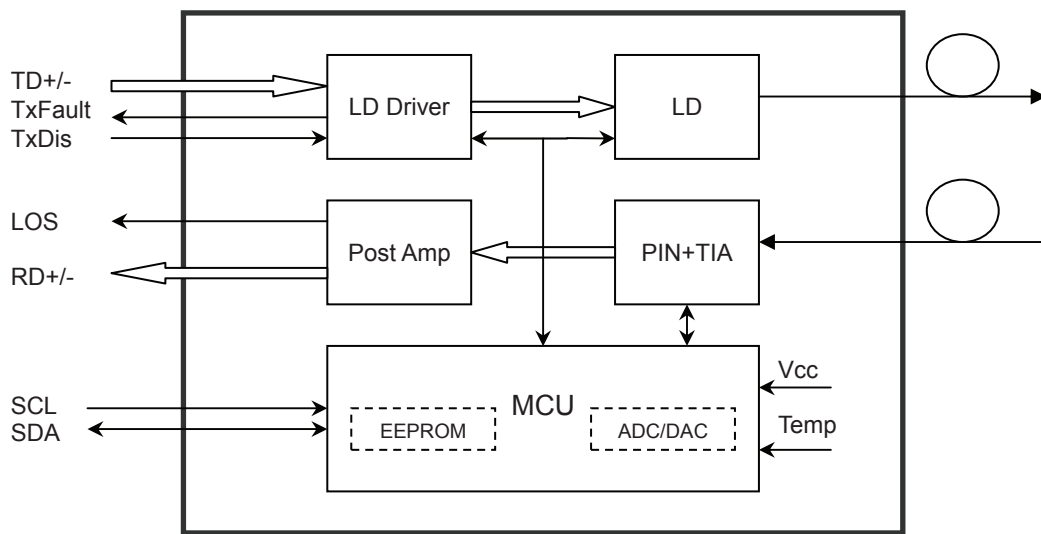

## Absolute Maximum Ratings

**Table 1 - Absolute Maximum Ratings**

Parameter	Symbol	Min	Max	Unit
Supply Voltage	Vcc	-0.5	4.5	V
Storage Temperature	Ts	-40	+85	°C
Operating Humidity	-	5	85	%

## Recommended Operating Conditions

**Table 2 - Recommended Operating Conditions**

Parameter	Symbol	Min	Typical	Max	Unit
Operating Case Temperature	Standard	0		+70	°C
		-20		+85	
	industrial	-40	+85	°C	
Power Supply Voltage	Vcc	3.13	3.3	3.47	V
Power Supply Current	Icc			300	mA
Data Rate			1.25		Gbps

## Optical and Electrical Characteristics

GP-8524-S5x(D): (VCSEL and PIN, 500m Reach)

Table 3 - Optical and Electrical Characteristics

Parameter	Symbol	Min	Typical	Max	Unit	Notes
<b>Transmitter</b>						
Centre Wavelength	$\lambda_c$	830	850	860	nm	
Spectral Width (RMS)	$\Delta\lambda$			0.85	nm	
Average Output Power	P <sub>out</sub>	-9.5		-3.5	dBm	1
Extinction Ratio	ER	9			dB	
Optical Rise/Fall Time (20%~80%)	tr/ta			0.26	ns	
Data Input Swing Differential	V <sub>IN</sub>	400		1800	mV	2
Input Differential Impedance	Z <sub>IN</sub>	90	100	110	$\Omega$	
TX Disable	Disable		2.0	V <sub>cc</sub>	V	
	Enable		0	0.8	V	
TX Fault	Fault		2.0	V <sub>cc</sub>	V	
	Normal		0	0.8	V	
<b>Receiver</b>						
Centre Wavelength	$\lambda_c$	770		860	nm	
Receiver Sensitivity				-18	dBm	3
Receiver Overload		0			dBm	3
LOS De-Assert	LOS <sub>D</sub>			-18	dBm	
LOS Assert	LOS <sub>A</sub>	-35			dBm	
LOS Hysteresis		1		4	dB	
Data Output Swing Differential	V <sub>out</sub>	400		1800	mV	4
LOS	High		2.0	V <sub>cc</sub>	V	
	Low			0.8	V	

**Notes:**

1. The optical power is launched into MMF.
2. PECL input, internally AC-coupled and terminated.
3. Measured with a PRBS 2<sup>7</sup>-1 test pattern @1250Mbps, BER  $\leq 1 \times 10^{-12}$ .
4. Internally AC-coupled.

## Timing and Electrical

**Table 4 - Timing and Electrical**

Parameter	Symbol	Min	Typical	Max	Unit
Tx Disable Negate Time	t_on			1	ms
Tx Disable Assert Time	t_off			10	µs
Time To Initialize, including Reset of Tx Fault	t_init			300	ms
Tx Fault Assert Time	t_fault			100	µs
Tx Disable To Reset	t_reset	10			µs
LOS Assert Time	t_loss_on			100	µs
LOS De-assert Time	t_loss_off			100	µs
Serial ID Clock Rate	f_serial_clock			400	KHz
MOD_DEF (0:2)-High	V <sub>H</sub>	2		V <sub>cc</sub>	V
MOD_DEF (0:2)-Low	V <sub>L</sub>			0.8	V

## Diagnostics

**Table 5 – Diagnostics Specification**

Parameter	Range	Unit	Accuracy	Calibration
Temperature	0 to +70	°C	±3°C	Internal / External
	-20 to +85			
Voltage	3.0 to 3.6	V	±3%	Internal / External
Bias Current	0 to 100	mA	±10%	Internal / External
TX Power	-9.5 to -3.5	dBm	±3dB	Internal / External
RX Power	-18 to -3	dBm	±3dB	Internal / External

## Digital Diagnostic Memory Map

The transceivers provide serial ID memory contents and diagnostic information about the present operating conditions by the 2-wire serial interface (SCL, SDA).

The diagnostic information with internal calibration or external calibration all are implemented, including received power monitoring, transmitted power monitoring, bias current monitoring, supply voltage monitoring and temperature monitoring.

The digital diagnostic memory map specific data field defines as following.

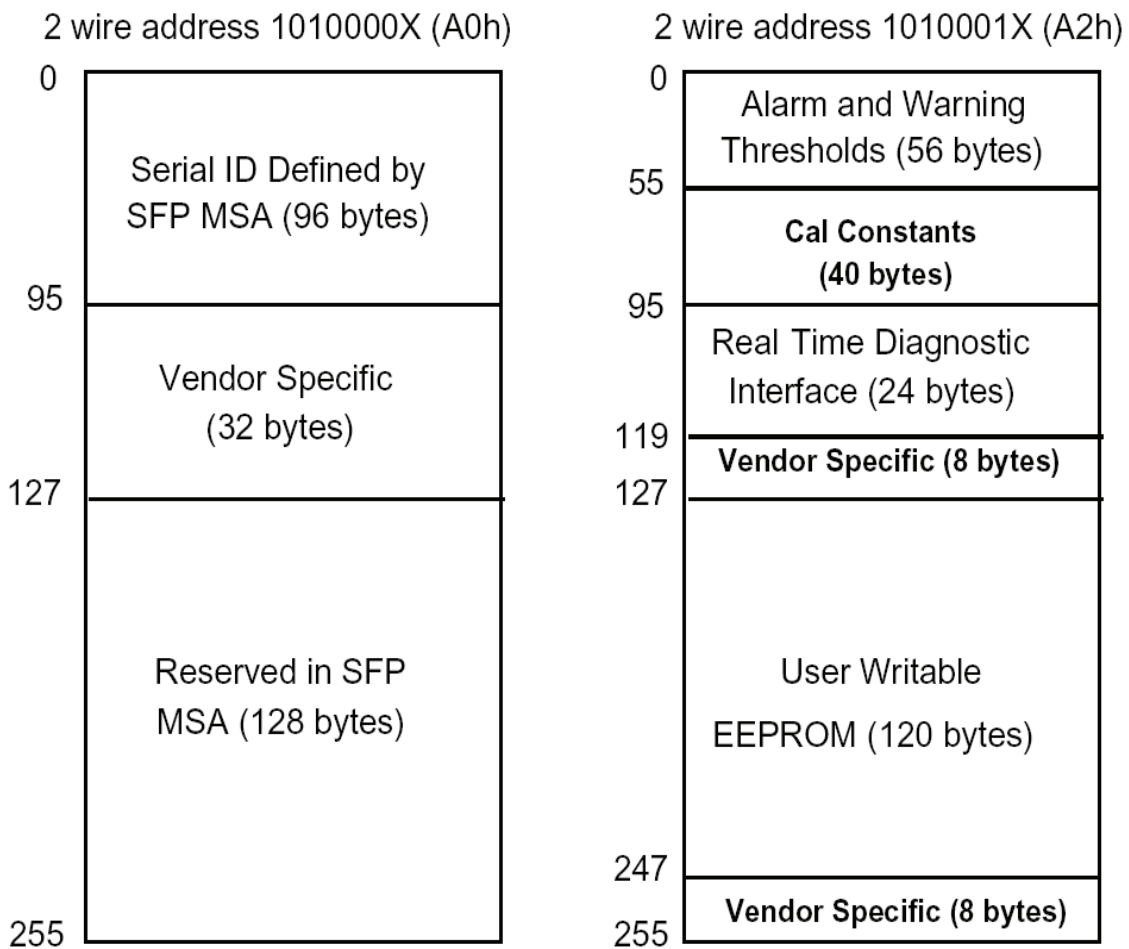

## Pin Definitions

Pin Diagram

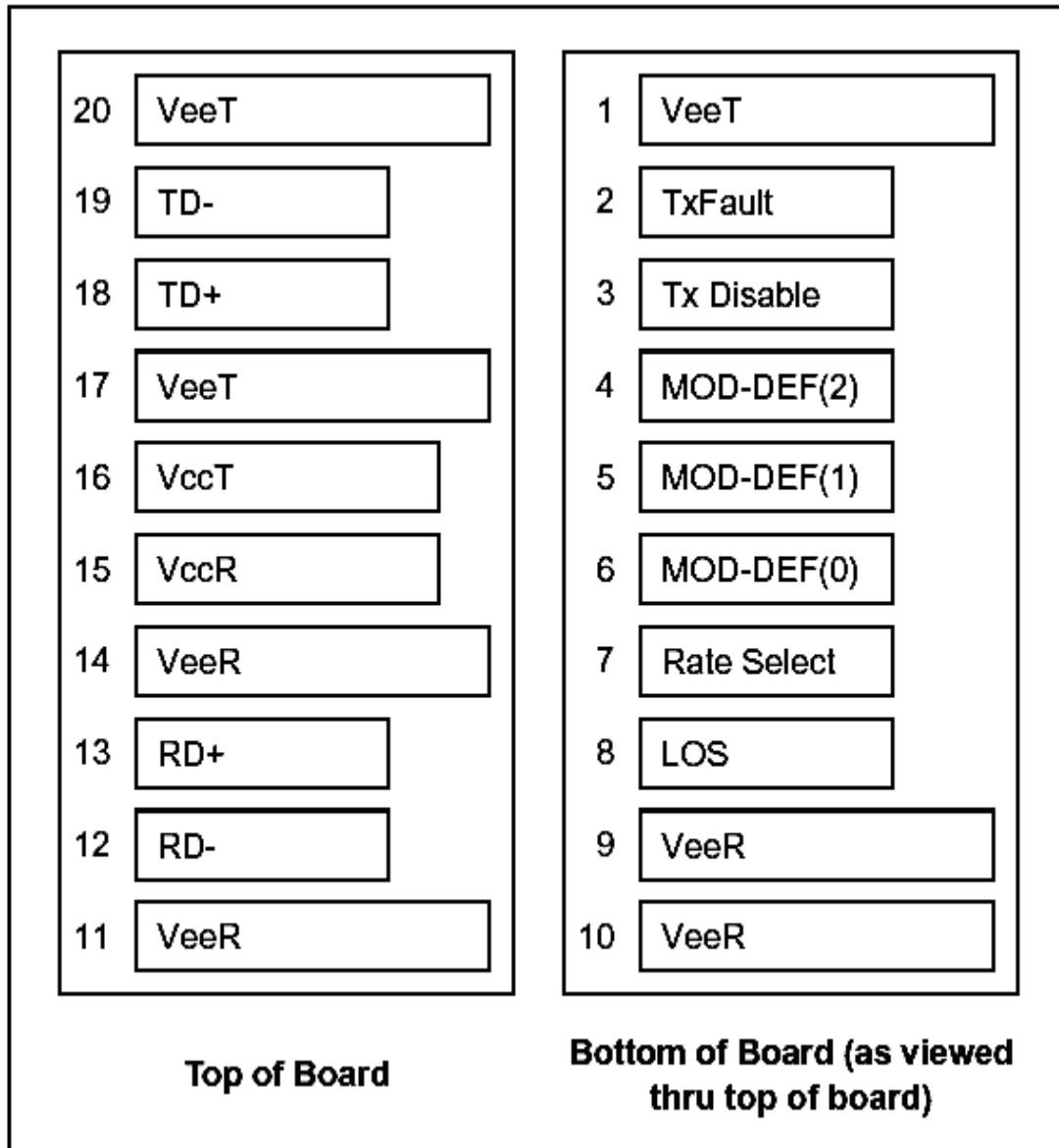

## Pin Descriptions

Pin	Signal Name	Description	Plug Seq.	Notes
1	V <sub>EET</sub>	Transmitter Ground	1	
2	TX FAULT	Transmitter Fault Indication	3	Note 1
3	TX DISABLE	Transmitter Disable	3	Note 2
4	MOD_DEF(2)	SDA Serial Data Signal	3	Note 3

5	MOD_DEF(1)	SCL Serial Clock Signal	3	Note 3
6	MOD_DEF(0)	TTL Low	3	Note 3
7	Rate Select	Not Connected	3	
8	LOS	Loss of Signal	3	Note 4
9	V <sub>EER</sub>	Receiver ground	1	
10	V <sub>EER</sub>	Receiver ground	1	
11	V <sub>EER</sub>	Receiver ground	1	
12	RD-	Inv. Received Data Out	3	Note 5
13	RD+	Received Data Out	3	Note 5
14	V <sub>EER</sub>	Receiver ground	1	
15	V <sub>CCR</sub>	Receiver Power Supply	2	
16	V <sub>CCT</sub>	Transmitter Power Supply	2	
17	V <sub>EET</sub>	Transmitter Ground	1	
18	TD+	Transmit Data In	3	Note 6
19	TD-	Inv. Transmit Data In	3	Note 6
20	V <sub>EET</sub>	Transmitter Ground	1	

**Notes:**

Plug Seq.: Pin engagement sequence during hot plugging.

- 1) TX Fault is an open collector output, which should be pulled up with a 4.7k~10kΩ resistor on the host board to a voltage between 2.0V and V<sub>cc</sub>+0.3V. Logic 0 indicates normal operation; Logic 1 indicates a laser fault of some kind. In the low state, the output will be pulled to less than 0.8V.
- 2) TX Disable is an input that is used to shut down the transmitter optical output. It is pulled up within the module with a 4.7k~10kΩ resistor. Its states are:
 

Low (0 to 0.8V):	Transmitter on
(>0.8V, < 2.0V):	Undefined
High (2.0 to 3.465V):	Transmitter Disabled
Open:	Transmitter Disabled
- 3) Mod-Def 0,1,2. These are the module definition pins. They should be pulled up with a 4.7k~10kΩ resistor on the host board. The pull-up voltage shall be V<sub>ccT</sub> or V<sub>ccR</sub>.
  - Mod-Def 0 is grounded by the module to indicate that the module is present
  - Mod-Def 1 is the clock line of two wire serial interface for serial ID
  - Mod-Def 2 is the data line of two wire serial interface for serial ID
- 4) LOS is an open collector output, which should be pulled up with a 4.7k~10kΩ resistor. Pull up voltage between 2.0V and V<sub>cc</sub>+0.3V. Logic 1 indicates loss of signal; Logic 0 indicates normal operation. In the low state, the output will be pulled to less than 0.8V.
- 5) RD-/+ : These are the differential receiver outputs. They are internally AC-coupled 100 differential lines which should be terminated with 100Ω (differential) at the user SERDES.
- 6) TD-/+ : These are the differential transmitter inputs. They are internally AC-coupled, differential lines with 100Ω differential termination inside the module.

## Recommended Interface Circuit

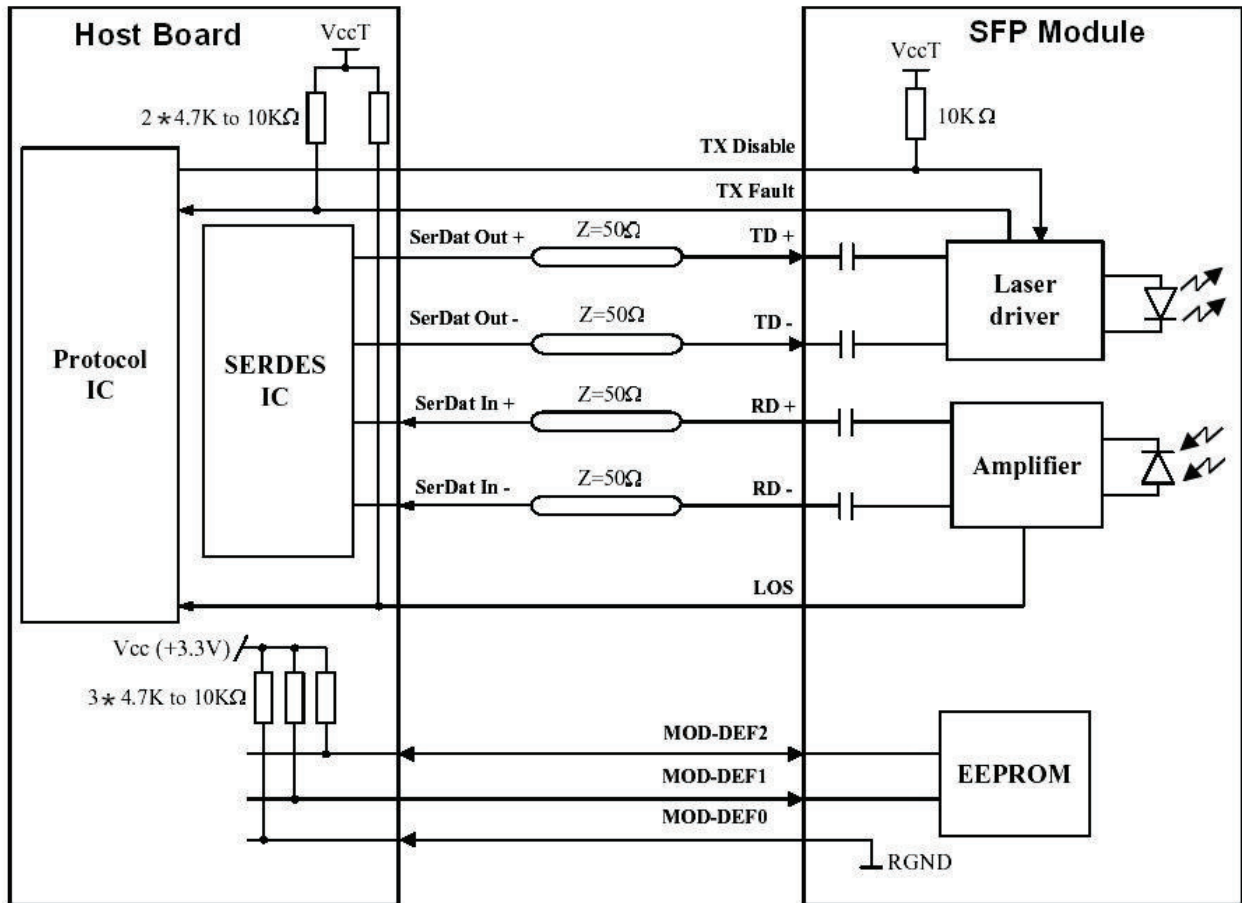



## Mechanical Dimensions

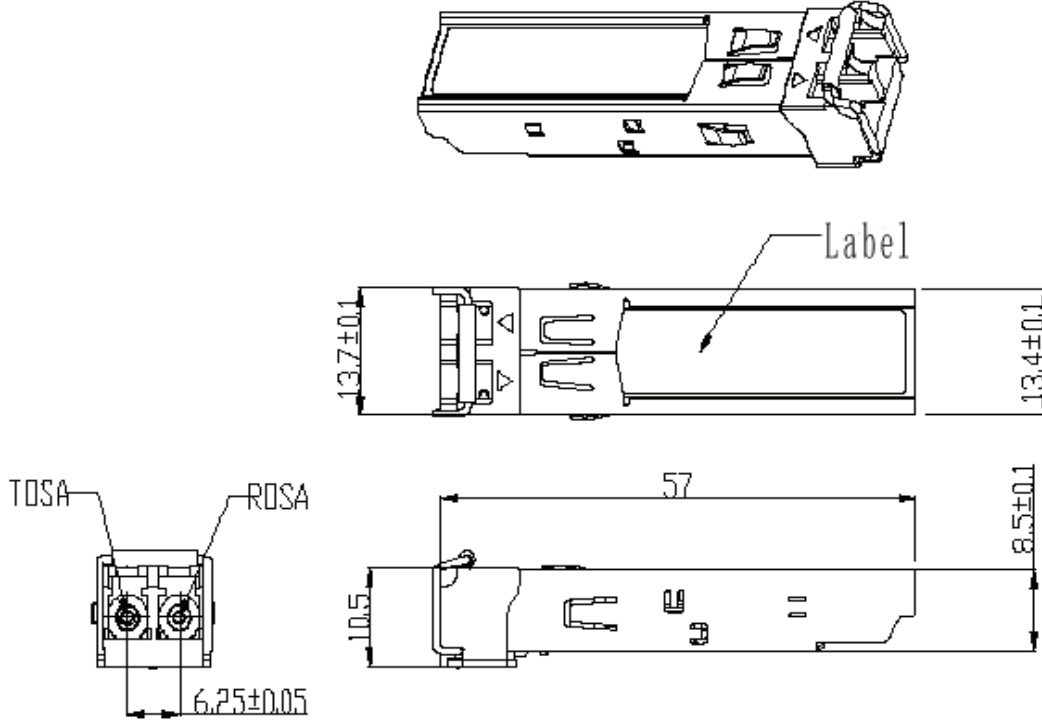

## Ordering information

Part Number	Product Description
MOD-IMGSX550-D	850nm, 1.25Gbps, 550m, -40°C ~ +85°C, With Digital Diagnostic Monitoring

Address : Perpa Ticaret Merkezi, A Blok No.295 Sisli/Istanbul | Tel : +90 212 3204030 | Fax : +90212 3200255 | e-mail : info@telcolink.com

[www.telcolink.com](http://www.telcolink.com)

© 2009 telcolink Inc. All rights reserved. Information in this document is subject to change without notice. All company names, logos, and product designs that are trademarks or registered trademarks are the property of their respective owners. 617-000175 Rev. C

